

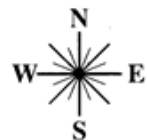

BARNSON PTY LTD

phone 1300 BARNSON (1300 227 676)
email generalenquiry@barnson.com.au
web barnson.com.au

RESIDENTIAL FOOTINGS DESIGN TO AS2870-2011



Central Darling Shire Council

D04/2023- PAN 310964

Section 4.16 (1) (a) of the

Environmental Planning and Assessment Act 1979

Approved by Council 12/05/ 2023

A handwritten signature in black ink, appearing to read "Reece Wilson". The signature is written in a cursive style.

Reece Wilson

Director Shire Services.

Client:

TEACHER HOUSING AUTHORITY

Project Address:

**75 COLUMBUS STREET
IVANHOE NSW 2878**

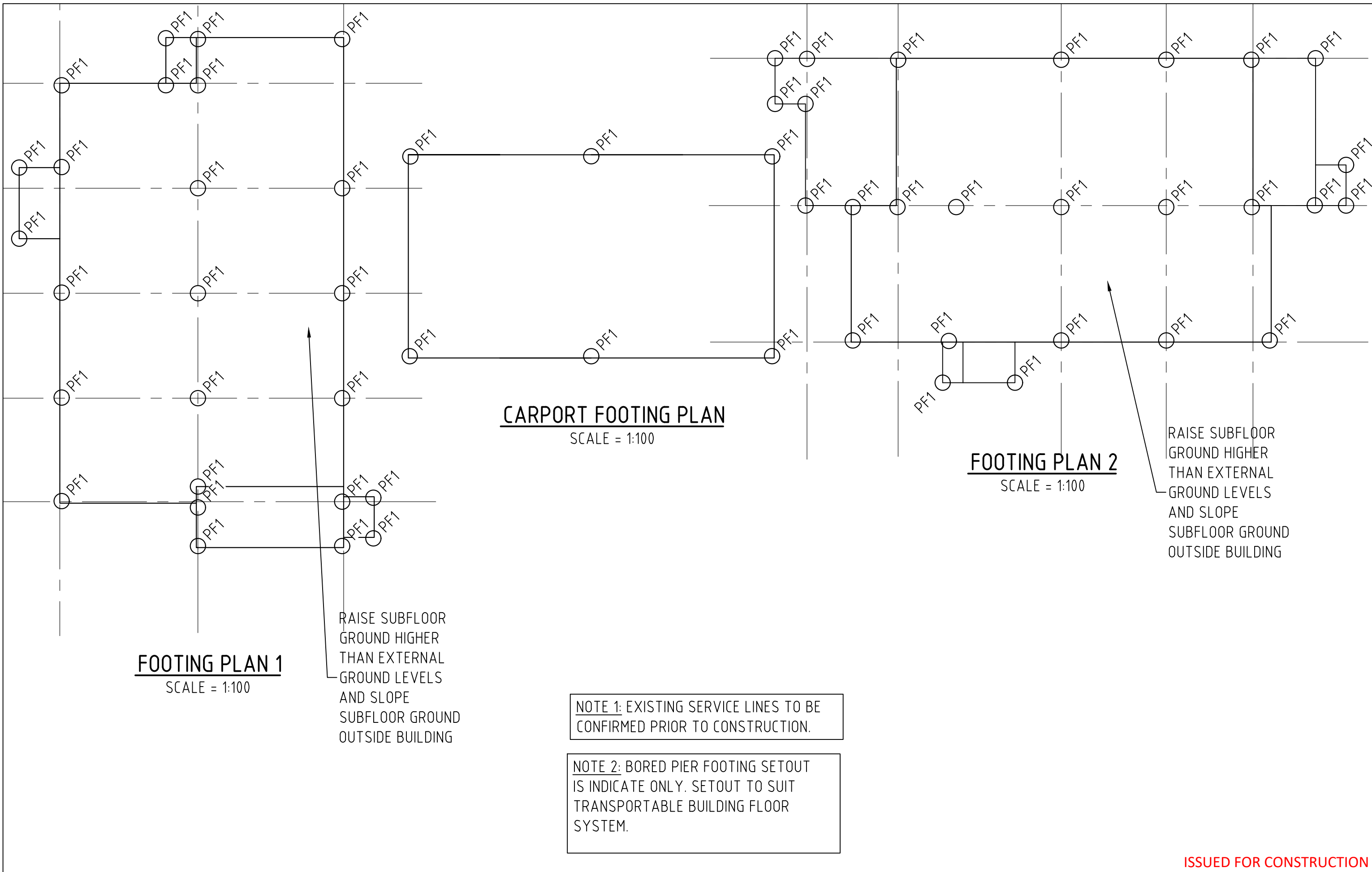

GEOTECHNICAL NOTES

1. THESE FOOTINGS HAVE BEEN DESIGNED FOR A CLASS "H2-D" SITE AS DEFINED BY AS2870-2011 BASED UPON GEOTECHNICAL REPORT BY BARNSON PTY LTD REFERENCE 39502-GR01_A DATED 10th AUGUST 2022.
3. ALLOWABLE BEARING CAPACITIES Q_a : TO BE CONFIRMED ON SITE:
A) PIER BASE > 150 kPa
4. SKIN FRICTION f_s : TO BE CONFIRMED ON SITE
A) PIER SHAFTS = 40 kPa

PIER FOOTING NOTES

1. CONCRETE EXPOSURE CLASSIFICATION = A1 TO AS3600-2009
2. CONCRETE IS TO BE GRADE N20 (20 MPa STRENGTH AT 28 DAYS AGE)
3. PIER DEPTH & WIDTH AS PER RELATIVE DETAILS
4. PIER REINFORCEMENT AS SPECIFIED IN RELEVANT DETAILS WITH 60mm COVER
5. SERVICES TO BE PLACED IN A 300mm WIDE x 450mm DEEP TRENCH A MINIMUM OF 600mm FROM EDGE OF BUILDING TO AVOID UNDERMINING OF FOOTINGS.

GENERIC DRAWINGS REFERENCE

THIS PLAN SHALL BE READ IN CONJUNCTION WITH THE FOLLOWING REFERENCE DRAWINGS WHICH FORM PART OF THE PROJECT SPECIFICATION: G1000, G1001, G1002, G1003, G1004, G1005, G1006, G1007 & 39694-S200 TO S200.

LEGEND

OPF1 PIER FOOTING

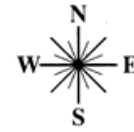

Central Darling Shire Council

D04/2023- PAN 310964

Section 4.16 (1) (a) of the

Environmental Planning and Assessment Act 1979

Approved by Council 12/05/ 2023

Reece Wilson

Director Shire Services.

ISSUED FOR CONSTRUCTION

BARNSON PTY LTD

phone 1300 BARNSON (1300 227 676)
email generalenquiry@barnson.com.au
web barnson.com.au

THIS DRAWING IS TO BE READ IN CONJUNCTION WITH GENERAL BUILDING DRAWINGS, SPECIFICATIONS & OTHER CONSULTANTS DRAWINGS APPLICABLE TO THIS PROJECT. ALL DIMENSIONS IN MILLIMETRES. DO NOT SCALE. DIMENSIONS TO BE CHECKED ON SITE BEFORE COMMENCEMENT OF WORK. REPORT DISCREPANCIES TO BARNSON PTY LTD. NO PART OF THIS DRAWING MAY BE REPRODUCED IN ANY WAY WITHOUT THE WRITTEN PERMISSION OF BARNSON PTY LTD.

Rev	Date	Description
A	17.03.2023	ISSUED FOR CONSTRUCTION

Project
TEACHER HOUSING DESIGN

Site Address
75 COLUMBUS STREET
IVANHOE NSW 2878
Client
TEACHER HOUSING AUTHORITY

Drawing Title
STRUCTURAL GENERAL NOTES

Design CB
Drawn AN
Check CB



Original Sheet Size
Revision

A3
A

Certification

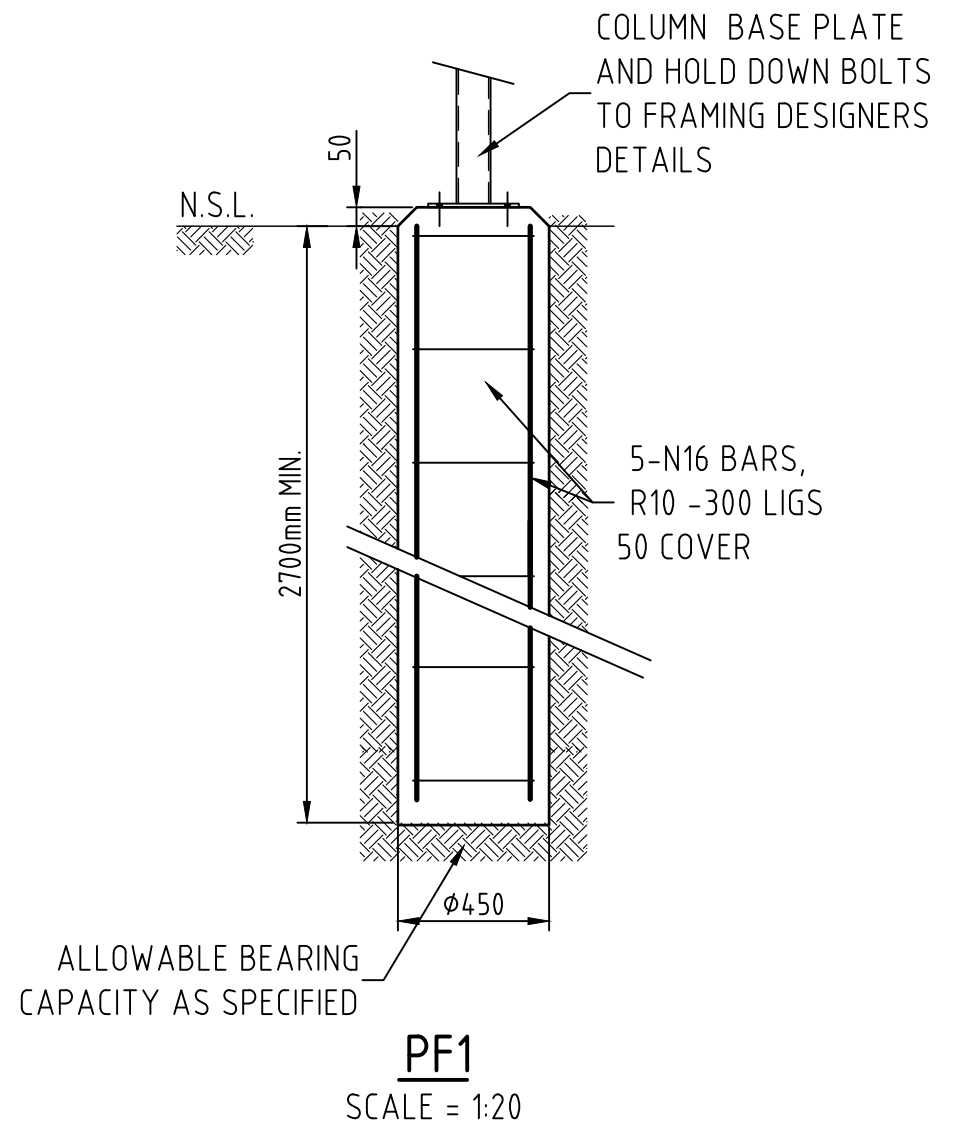
Project No 39694
Drawing No S201



 Central Darling Shire Council
 D04/2023- PAN 310964
 Section 4.16 (1) (a) of the
Environmental Planning and Assessment Act 1979
 Approved by Council 12/05/ 2023

 Reece Wilson
 Director Shire Services.

ISSUED FOR CONSTRUCTION